



**Pistol Fort-12
caliber 9 mm Makarov**

SIA «Fort» of the MIA of Ukraine
600-richchya Street 27
Vinnitsa, 21027, Ukraine
tel. (0432) 46-73-26
fax (0432) 46-80-16
siafort@ukr.net

Operational Manual

28 firing-pin plug
29 ejection slot
30 extractor
31 extractor plunger
32 extractor spring
33 safety lever plunger
34 safety lever spring
35 slide stop
36 magazine catch button
37 magazine catch spring
38 rear sight
39 front sight
40 pins of back strap of the pistol grip
41 magazine body
42 magazine floor plate
43 magazine base
44 magazine follower
45 magazine spring
46 rear sight holder

This operation manual is intended for the learning of the principle of action and rules of operations of pistol Fort-12 caliber 9 mm Makarov (hereinafter - pistol), and contains information about the design, operating procedures, safety requirements, disassembly and assembly rules, cleaning, greasing, storage and guarantee statement.

You must always keep in mind that the pistol is a source of higher risk and can become the reason of unpredictable consequences both for shooter and surrounding people.

It always necessary to follow below safety indications to alert risks:

1 Only clean pistol is suitable for shooting.

2 Always handle with the pistol as if it is loaded and ready to shoot.

3 Always point the barrel in safe direction no matter if pistol is loaded or not.

4 The safety lever must be in the "safe" position when the pistol is not used and after shooting.

5 Clean and grease the pistol after shooting.

1 PISTOL DESCRIPTION

1.1 Function

The pistol is designed for aimed fire for distances up to 50 meter. The pistol is a personal weapon for law enforcement and military personnel, which perform the respective functions assigned to them by law.

1.2 Technical data

Callber	9 mm Makarov
Magazine capacity/rounds	15
Dimensions, mm, not more	
Overall length	180
Overall height	131
Overall width	33
Weight with an empty magazine, kg, not more.....	0,83

1.3 Pistol completeness

Pistol w/o magazine.....	1 pce
magazine	2 pcs
wiper	1 pce
operation manual	1 pce
individual package	1 pce

1.4 Safety measures

1.4.1 It is forbidden to leave the pistol with hammer in cocked position even if it is unloaded.

1.4.2 Inspect to be sure that manual safety lever is in the "safe" position (red dot on the slide is covered by safety lever) in such cases:

- when firing is finished,

List of parts for figures 1, 2, 3

- 1 frame
- 2 slide
- 3 back strap of the pistol grip
- 4 magazine
- 5 safety lever
- 6 barrel with cartridge chamber
- 7 recoil spring
- 8 recoil spring guide
- 9 trigger
- 10 trigger axis
- 11 trigger bar spring
- 12 trigger bar axis
- 13 trigger bar
- 14 sear housing with ejector
- 15 sear
- 16 sear axis
- 17 sear spring
- 18 interrupter
- 19 hammer
- 20 hammer axis
- 21 pusher
- 22 pins of the pusher and firing spring stop lever
- 23 firing spring
- 24 firing spring lever
- 25 firing spring stop
- 26 firing-pin spring
- 27 firing-pin

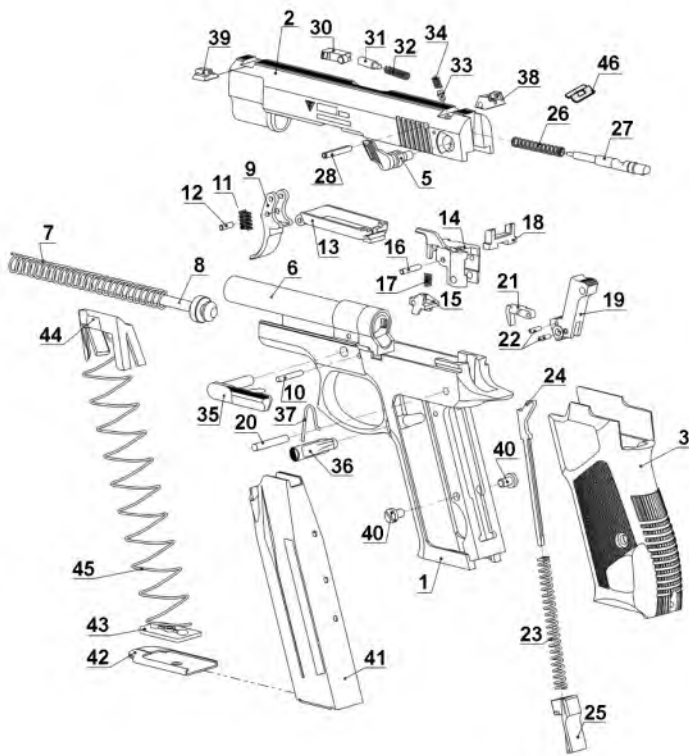

Figure 3

28

- during inserting magazine into the pistol handle,
- when the pistol is not used.

1.4.3 It is forbidden to point the pistol at people or pets even if you sure that it is unloaded.

1.4.4 To identify the causes of firing delays first pull out the magazine and then check the pistol.

1.4.5 It is absolutely forbidden to use petrol or other flammable liquids, abstergents or soivents for pistol cleaning.

1.4.6 It is forbidden to use for firing ammunition with corrosion, with dents or loosened cartridge primer.

1.5 Pistol design

This pistol is self-loading, provides only single shot firing while single pressing of the trigger.

Feeding mechanism is with magazine ammunition feeding and provides feeding of cartridges to loading line.

Breech mechanism is intended for locking and unlocking of barrel bore - blowback operated; slide is not locked with barrel while shot and recoil after shot.

Trigger mechanism (which activates the hammer) is double action and provides fire as with pre-cocked hammer, so with self-cocking firing.

Firing mechanism, which puts into operation percussion primer of cartridge, is hammer type.

The appearance and location of the pistol controllers are given in figures 1 and 2, and the location of the pistol parts in figure 3.

The pistol consists of:

- frame, which is made of the reinforced polymer

5

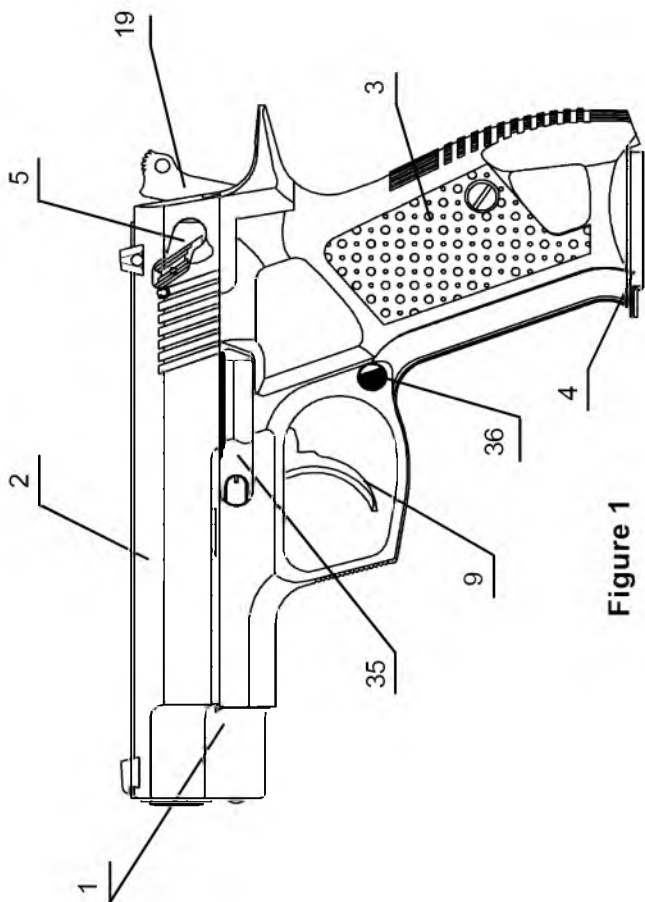

Figure 1

The energy of powder gases pushes the cartridge forward along the barrei and forces the slide to move back.

The moving back slide presses the recoii spring, extracts the case by the extractor from the cartridge chamber. The case ejects outside after the contact with the ejector through the ejection slot. The interrupter runs out from the siide holes, falls down and pushes back end of the trigger bar low of sear shoulder-blades. Under the pressure of the sear spring the released sear braces to the hammer surface, which is pressed by the siide.

Under the influence of compressed recoii spring the siide moves forward, chambers the cartridge from the magazine to the cartridge chamber, hammer is holding by sear in cocked position.

Siide closes the cartridge chamber after reaching of front position, extractor hook enters into case groove of cartridge, interrupter enters into siide notches, it goes up and releases back end of the trigger bar. While releasing of the trigger, trigger bar moves forward, back end of the trigger bar goes up under the pressure of trigger bar spring and places opposite sear's shoulders. Pistol is again ready to shoot.

1.6.2. Pistol operation while self-cocking fire

Trigger is in the half-cock position, firing spring is released, and safety lever is in "fire" position.

A shot is carrying out by pressing on the trigger, which turns hammer around an axis through the trigger bar and pusher, and compresses the firing spring, simultaneously, trigger bar turns the sear and excludes the possibility for hammer to stay in the full cock position.

26

7

material; barrel, which is rigidly fixed in the frame; slide, which glides in the frame grooves; magazine, inserted into the pistol handle;

- metal frame;
- hammer type and double action trigger mechanism, which is located in the frame. It allows making a shot as with pre-cocked trigger, and by self-cocking;
- recoil spring, which is located under the barrel and surrounds the guide;
- safety lever which in the "safe" position provides: blocking of slide with frame, sear and hammer blocking, on both positions - when hammer is cocked or half-cocked. The safety lever ledge is located in front of firing pin, which prevents striking of firing pin by hammer;
- slide stop lever, that holds the slide in rearmost position after the fire by last cartridge from the magazine. When slide stop lever is pressed down, slide sets in forward position;
- open-type sights - front and rear sight.

1.6 Operation concept of the pistol

1.6.1 The pistol firing operation with pre-cocked hammer

Hammer holds in the cocked position by the sear, firing spring is compressed, and safety lever is in the "fire" position, cartridge is in the cartridge chamber.

A shot is carried out by pressing the trigger, which turns the sear through the trigger bar and releases the hammer. Under the pressure of firing spring released hammer strikes the firing pin, which breaks the percussion primer. The shot is happened.

6

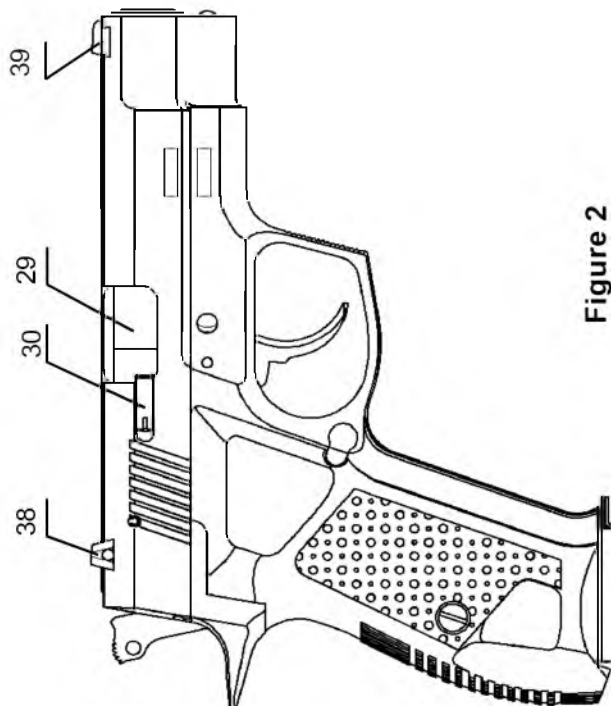

Figure 2

27

When the hammer become in unstable position, while turning around an axis, compressed firing spring expands and forces the hammer to strike the firing pin, which breaks the percussion primer. The shot is happened.

Further work of the pistol is described in section 1.6.1 of this manual.

1.7 Marking

At the pistol side should be applied the following marking: manufacturer trademark; shot title of the pistol - Fort-12; proper caliber - 9 mm Makarov; words "Made in Ukraine". Serial number is applied on the pistol frame and side.

1.8 Packing

The pistol in completeness according to the section 1.3 of this manual is packed in individual package, which is suitable for storage.

2 OPERATING INSTRUCTIONS

2.1 Safety instructions

2.1.1 Always follow the safety instructions for your safety and safety of others.

Carry the checking of pistol safety in following cases:

- when receiving or transferring the pistol;
- upon arrival to the place of fire;
- after the end of each shooting;
- before leaving of the shooting range;
- before conducting of maintenance.

8

9 WARRANTY

The manufacturer guarantees conformity of the pistol to the requirements of normative documents at the observance of the exploitation rules, transportation and storage, which are described in this manual.

The warranty is 12 months from the day when the pistol was sale.

SIA «FORT» removes discovered defects during the warranty free of charge, under the condition of observing all rules of exploitation and pistol storage, which are mentioned in this manual.

For fulfilling of the guarantee repair the owner must send the pistol and this manual to SIA «FORT» to address:

600-richchya Street, 27, Vinnitsa, 21027, Ukraine

SIA «FORT» repairs the pistol after the end of warranty for the owner's cost.

10 INFORMATION ABOUT PRESERVING AND PACKING

Pistol Fort-12 caliber 9 mm Makarov, factory number _____, is preserved and packed in accordance with requirements of the valid technical documents.

Executed preservation _____

Executed packing _____

Preservation date " ____ " _____ 20 ____

L.S.

25

6 STORAGE OF THE PISTOL

For a long-term storage of the pistol it is necessary to carry out its preserving. Preserving procedure is done in the section 3.10 of this manual. Wrap up the pistol with paper after preservation.

Preserved and packed pistols must be stored in closed storehouses, where temperature and humidity fluctuation are less than in open air.

Maximum storage term of the preserved pistol is no more than one year from the preserving.

7 TRANSPORTATION

The pistol in the original packing get transported by any transport for any distances: in the covered railroad car, covered cars, air-tight apartments of airplanes in accordance with rules of transportation with the proper transport. During the transportation must be assured position of boxes, which excludes the possibility of their strokes at one another.

8 CERTIFICATE OF ACCEPTANCE

Pistol Fort-12 caliber 9 mm Makarov, factory number _____, is made and accepted in accordance with requirements of normative documents, technical documents and this pistol is recognized as suitable for exploitation.

Executed acceptance _____

L.S. " " _____ 20____

Sold _____

L.S. " " _____ 20____

5 POTENTIAL PROBLEMS

Common troubles and remedies are listed in the table 5.1

Table 5.1

Name of failure	Hypothetic cause	Troubleshooting method
Misfire. The slide is in forward most position, the hammer is deflated, but the shot is failed	1. Cartridge defect 2. Condensation of lubricant, pollution or jamming of firing pin 3. Precipitating or fracture of the hammer spring	1. Reload the pistol. Continue the shoot. 2. Unload the pistol, disassemble it, inspect and clean it. If the firing-pin is jammed, send the pistol to the workshop. 3. Unload the pistol and send it to the workshop
Delay of cartridge by the slide. The slide stopped without reaching of forward most position.	1. Cartridge chamber pollution 2. Damage or precipitation of recoil spring	1. Push the slide manually forward and go on fire. 2. Discharge the pistol and send it to the workshop.
Cartridge-case jamming by the slide. Slide is at mid position	1. Contamination of pistol moving parts. Poor round charge. 2. Ejector defect.	1. Disconnect the magazine, take the slide back, throw away the cartridge-case and go on fire. 2. Unload the pistol and send it to the workshop.

2.1.2 To test the safety of the pistol, follow steps below:

- check the safety lever; make sure that it is set in a "safe" position;
- make sure that the magazine is disconnected from the pistol;
- point the barrel of the pistol in a safe direction;
- put the safety lever in the "fire" position;
- while holding the barrel of the pistol in a safe direction, move side in rearmost position, check the cartridge chamber through the ejection slot, make sure that it is empty, release the side;
- by holding the barrel of the pistol in a safe direction, press the trigger (control shot);
- set the safety lever in the "safe" position.

2.2 Magazine loading

Grasp the magazine in upright position, and put cartridge on follower, ahead magazine lips. Press on the cartridge and push it under the magazine lips, in the same way press another cartridges. To extract cartridges of the magazine, press the case bottom of cartridges by thumb in the forward direction.

2.3 Loading and firing instructions

2.3.1 Make sure that the safety lever is in the "safe" position.

Insert loaded magazine into the pistol handle. Keystroke of the magazine catch button is accompanied by a specific sound.

2.3.5 After the end of the shooting, if not all rounds are used the side is in forward position. Move the safety lever in the "safe" position. If cartridges are fully used side is held by side stop in the rearmost position. Press the side stop lever down, side will set to the forward position; remove the safety lever to the "safe" position.

2.4 Unloading instructions

2.4.1 Press the magazine catch and remove the magazine.

2.4.2 Check the pistol safety as stated in 2.1.2 of this manual.

2.4.3 If cartridge was in the cartridge chamber during checking of the pistol safety, it will be ejected from the cartridge chamber. Pick ejected cartridge.

2.4.4 Remove unused cartridges from the magazine, as stated in 2.2 of this manual; insert an empty magazine into the pistol handle.

2.5 Handling operations in case of firing delay

The list of delays and handling operations is below:

1) if you press the trigger and hammer is released, but the shot failed - reload the pistol and continue the shooting;

2) side did not reach the extreme front position after automatic reloading, hammer is not released - move by hand the side forward and continue the firing, If it is impossible, follow actions according to item 3;

3) during automatic reloading when the cartridge is jammed between the face of side and breech - point

2.3.2 For shooting with pre-cocked hammer, point the barrel in a safe direction, turn the safety lever to "fire" position. Draw the slide in rearmost position and release it. The pistol is loaded and ready for the shot (cartridge is in the cartridge chamber, hammer is cocked).

Aim and press the trigger. After first shot, the hammer cocking; case ejection through the ejection slot and next cartridge feeding to the chamber will be performed automatically. To continue fire you must release and press the trigger till using all magazine rounds.

2.3.3 For fire in self-cocking mode, point the pistol barrel in a safe direction. Put safety lever to "fire" position. Draw the slide in rearmost position and release (cartridge is in the chamber, the hammer is cocked). Holding the hammer with thumb, press the trigger and slowly move the hammer from full cock to half-cock position. Pistol is ready to self-cocking fire.

During the execution of the self-cocking shot, aim, press the trigger, after first shot hammer cocking, case ejection through the ejection slot and feeding of new cartridge into the chamber from the magazine - will be performed automatically. Release and again press the trigger to continue the shooting.

2.3.4 After shot by last cartridge from the magazine, the slide is held by slide stop in the rearmost position. Magazine is empty. To continue the shooting, press magazine catch button and support the drop-down empty magazine. Insert the loaded magazine into the handle. Press the slide stop lever down. Pistol is loaded again and ready to fire.

the barrel in a safe direction, press the magazine catch button and disconnect the magazine, draw the slide back, pull out jammed cartridge, insert loaded magazine, reload the pistol and continue the shooting.

3 MAINTENANCE INSTRUCTIONS

3.1 General

Carry out maintenance of the pistol immediately after end of the shooting.

With a large number of shoots for one day, carry maintenance after every 250 shots.

If the pistol is not used, maintenance must be made weekly.

Sequence of the maintenance:

- disassemble the pistol and magazines;
- clean the pistol and magazines;
- check the disassembled pistol;
- lubricate and assemble the pistol;
- check the operation of the pistol after assembling.

3.2 Preparation for the disassembly

Point the pistol barrel in safe direction, press the magazine catch button and support the drop-down empty magazine.

Check the safety of the pistol, as described in 2.1.2 of this manual.

3.3 Field stripping instructions

Make sure that the magazine is disconnected, set the safety lever to the "fire" position.

End of table 5.1

Name of failure	Hypothetic cause	Troubleshooting method
Pinching of the cartridge between face of the slide and breech end of the barrel while sending the cartridge to the chamber	<ol style="list-style-type: none"> 1. Magazine pollution 2. Straightening of magazine lips 3. Magazine is not fixed by magazine locking button 	<ol style="list-style-type: none"> 1. Disconnect the magazine, take the slide back, pull out the pinched cartridge. Continue the shoot. 2. Unload the pistol, change the magazine. Send the defective magazine to the workshop. 3. Pull out the magazine. Take the slide back, pull out the damaged cartridge. Insert the magazine. Continue the shoot.
Automatic fire	<ol style="list-style-type: none"> 1. Interrupter defect 2. Damage of the hammer stud or sear 3. Damage or weakening of the sear spring 	In any case unload the pistol and send it to the workshop.

Front sight dimensions are in the Table 4.2.
Table 4.2

Number	1	2	3
Height, mm	4,5	4,7	4,9

Removing of rear sight right (left) for 1 mm changes MPI locating in respective side for 19 cm.

Zeroing of the pistol is considered as finished, when pistol meet the requirements of zeroing for accuracy of fire and MPI.

After zeroing of pistol it is necessary to mount rear sight by center punch.

determine MPI by following method:

- connect neighbor's holes with bee-line by pairs, direct thrd line through the centre of both lines and divide in half this distance. Received point will be a MPI;

- connect holes by pairs across with bee-line; the point of crossing is a MPI.

To determine the MPI according to three hoies it is necessary to connect the two holes with bee-lines and the distance between them divide in half, to connect received point with the third hole and divide distance between them into three parts. MPI is the related point to the first two holes.

After defining the MPI, measure the distance between the MPI and CPI.

MPI has not deviate from CPI for more than 5 cm in any direction. If MPI deviates from the CPI for more than 5 cm, it is necessary to relocate or change rear sight. The rear sight is replaced for lower (higher) rear sight if MPI is higher (lower) than CPI; rear sight is removed left (right) if MPI is right (left) than CPI.

Increase (decrease) of rear sight height or front sight height provides removing of impact point up or down.

Rear sight dimensions are in the Table 4.1.

Table 4.1

Number	1	2	3	4	5
Height, mm	5,7	5,85	6,0	6,15	6,3

3.10 Preserving

The manufacturer carries out preservation of the pistol. Maximum term of the pistol storage without repeated preservation is no more than one year.

For depreservation of the pistol it is necessary to carry out its disassembly and cleaning, in accordance with section 3 of this manual.

At achieving of the maximum term of its storage or in case when the pistol is not used for a long time, it is necessary to carry out depreservation by using of the method of putting thick layer of gun oil on its internal and external surfaces.

Use the wiper, which is included in the set of supply, square of cloth and gun oil during carrying out of the pistol preservatlon and depreservation.

4 CHECKING AND ZEROING

4.1 General

The pistol must be basically zeroed.

Checking of the pistol action is carrying out:

- after receiving of the pistol by the subdivision;
- after workshop repair;
- when detected during the shooting the deviation of impact point from the control point more than five cm.

4.2 Pistol zeroing

Zeroing of the pistol is executed by shooting from the distance on 25 m with cartridges from the same box.

Fire is leading on the target - a black circle with diameter of 25 cm, fixed on shleld with helght 1 m of width 0,5 m.

Lift up the rear edge of the siide stop lever and then press the slide stop axis by wiper or magazine. Remove the slide stop.

Draw the siide in rearmost position, lift up the rear of the siide, and by releasing it forward remove it from the barrel. Remove the recoil spring guide with recoil spring from the frame, disconnect the recoil spring from its guide.

3.4 Complete disassembly of the pistoi

It is not recommended to carry out complete disassembly often, because it leads to premature wear of the pistoi mechanism.

Carry out complete disassembly only in case of strong pollution or operation in severe conditions (rain, snow, sand dust, high humidity). Carry out field stripping of the pistoi as directed by section 3.3 of this manual.

Holding the hammer with your thumb, press the trigger, slowly pull the hammer from full cock to half cock.

By drift pin push the pin of the handle back strap, and disconnect it from the frame.

By the wiper push up the firing spring stop till firing spring stop will unhook with the frame. Disconnect firing spring stop from the firing spring lever; remove the firing spring from its lever.

Push out the hammer axis by drift pin or by hammer spring lever. Pull out sear housing with ejector from the frame, pulling it upwards, and then pull the interrupter and hammer. Push out the sear axis from the housing and remove the sear and sear spring.

By wiper through the slot of handle deflect the rlght

3.6 Cleanng of the pistoi

Pistoi cleaning should be done by special lubricating oil in following sequence. Cleanng of the barrel bore in the following order:

- stretch square of cloth through the wipe port. Mat thickness of cioth should be such that the wiper enters into the barrel bore with little effort;
- moist the cloth by weapon oii;
- insert the wiper in the barrel bore and slowly slide it along the length of the bore several times;
- replace the cloth and clean again;
- repeat cleaning as long as on a clean cioth will not remain traces of dirt or soot;
- wipe dry the barrel bore by clean and dry cloth.

Clean the siide from dirt and moisture with a cloth, moistened with weapon lubricating oil and squeezed. Thoroughly clean places around ejector and firing pin. The rest of details and mechanisms, as well as magazine body, wipe dry with a cioth to complete removal of traces of soot, dirt and molsture.

NOTE. During flrst cleanng it is necessary to clean storage compound, carefully wiping details with the square of cloth, which is slightly moistened by weapon lubricatng oii and squeezed out.

3.7 Inspection of the disassembled pistoi

Carry the inspection of the disassembled plstoi after cleanng.

There should not be any defects on details that

(curved) end of magazine catch spring left and up so, that curved end runs out of deepening of the button, by holding compressed spring pull out it direct end from button hole, push the spring out of the frame groove, then pull the magazine catch button out of the frame hole.

Push out the trigger axis by drift pin and pull down the trigger so, that the joint of the trigger with trigger bar exit out of the frame. Push out the trigger bar axis by drift pin, and disconnect the trigger from the trigger bar. Pull the trigger bar through the up slot of the frame, then the trigger with trigger bar spring. Pull the trigger bar spring from the trigger hole.

By wiper press on rear of the firing pin against stop. By turning the safety lever, pull it from the siide hole.

By drift pin push out the firing-pin plug at right or left side of the slide. Holding by hand the firing pin, pull out the drift pin, then pull the firing pin from slide channel.

Press by wiper the extractor plunger, while pressing the forward part of the extractor by the finger and, turning it around the hook end, pull from the slide seat. Remove the plunger and spring from the slide hole.

3.5 Magazine disassembly

Before disassembly of the magazine, take out all cartridges. Press the catch of the magazine floor plate by the drift pin and carefully move it forward, holding the bottom of the magazine. Pull out the bottom and magazine spring with follower.

14

affect the working capacity, durability and safety of the pistol, namely:

- there must be no deformation, swellings and splits on the barrel and chamber;
- there must be no crack, stratifications, metal breach on the slide;
- there must be no breaks, especially in the back part and the seat of the hammer, on the frame;
- the firing pin should move freely in the siide channel;
- there must be no chips on the extractor hook and hammer head;
- there must be no cracks and layers on magazine lips;
- magazine lips must not be deformed;
- all details of the pistoi must have no any disunities, deformations and blight.

3.8 Lubrication and assembly of the pistoi

After cleaning and inspection of the disassembled pistoi, lubricate components and pistol mechanism by weapon lubricating oil.

Apply a thin coat of oil with a cloth moistened with oil and squeezed out.

Remove oil flows by dry cloth.

Carry out assembling of the pistoi and magazine in the reverse sequence as described in section 3.3 "Field stripping instructions", 3.4 "Complete disassembly of the pistoi" and 3.5 "Magazine disassembly".

16

Point of impact must be in the middle of lower end of black circle or on its centre. Point of impact must be approximate to eye level of shooter.

Normal location of mean point of impact (MPI) is marked under the point of impact by lead line (using chalk or color pencil). MPI must be higher than aiming point (AP) for 12.5 cm or coincide with it, if the centre of cycle will be the AP. Marked point will be control point of impact (CPI).

In order to zero the pistol, shooter should execute four shots, one after another, with same aiming direction. Depending on holes position, determine accuracy of fire and location of MPI. Accuracy of fire is considered as normal if all of four hoies (or three, with one of which is obviously deviated) fit the diameter of 15 cm.

If the accuracy of fire is satisfactorily, then determine the MPI and measure the deviation from CPI. For easier detection draw two lines though the CPI - horizontal and vertical.

In order to determine the MPI of four holes, it is necessary to connect two closest hoies with the direct line and divide this distance in half; received point of division must be connected with the third hole. Then divide this distance for three equal parts; point of division, which is the nearest to the first two hoies, must be connected with the fourth hole and then divide this distance for four equal parts. The point, which is situated on three positions from fourth hole, will be the MPI.

If holes are symmetrically located it is possible to

19

3.9 Inspection of the pistoi function

Without inserting magazine into the pistoi handle, point the pistoi barrel in a safe direction, turn the safety lever to "fire" position.

Take the slide in rearmost position and inspect the chamber through ejection slot, it must be empty.

Release the slide; under the action of recoil spring it has to set in forward position, the hammer should remain on cocked position.

Press the trigger (idle). Put safety lever in the "safe" position. The hammer is fixed in the safety position. Slide is coupled with the frame. While pressing the trigger (self-cocking) hammer is not cocked. Put the safety lever in "fire" position, cock the hammer by pressing it by thumb, and set the safety lever in the "safe" position. Press the trigger. The hammer is fixed and it does not cut down from cocked position, siide is coupied with the frame.

Insert an empty magazine and check its fixation in the pistoi handle.

Put the safety lever to "fire" position, pull the slide in the rearmost position and release it. The siide is held in rearmost position by siide stop. Press the slide stop lever, slide sets in front position, the hammer is cocked, press the trigger.

Pull out the magazine, draw the siide in rearmost position and release, the slide sets in front position, the hammer is cocked, press the trigger, the hammer strikes the firing pin. Press the trigger, the hammer cocks and it does not set in half-cock position, strikes the firing pin (self-cocking firing). Put the safety lever in "safe" position, insert the magazine.

17